

Two response tests of two « identical » boreholes drilled to a depth of 160 m near Luzern

Dr. D. Pahud
LEEE – DCT
SUPSI
CH – 6952 Cannobio

daniel.pahud@dct.supsi.ch
<http://www.leep.dct.supsi.ch/>

Abstract

The analysis of two response tests performed on two borehole heat exchangers drilled close to each other and constructed with the same design shows that the estimated ground thermal conductivity differs by 10%. Possible sources of error are examined and quantified in order to explain the difference. This analysis also highlights the sensitivity of a response test to outside conditions and, when the line source approximation is used, to the stability of the heat injection rate.

Introduction

In the framework of the construction of the new SUVA buildings at Gisikon, near Luzern, a diffusive ground heat storage will be integrated in the energy concept of the buildings. The task is to size the storage as part of a complete heating and cooling system. This requires knowledge of the time-evolution of the heating and cooling demand for a typical year, as well as the thermal properties of the ground and the borehole heat exchangers that will form the ground heat exchanger of the heat storage. The annual heating and cooling energy requirements were estimated to 1'510 MWh/year and 730 MWh/year respectively.

Two response tests were realised to determine in situ the main thermal parameters of the ground and borehole heat exchangers (Pahud, 1999). They used two boreholes of 152 mm diameter equipped with a double U-pipe installation 160m deep. The two boreholes, placed approximately 30 m apart, will be reused in the actual storage.

In this paper, the two response tests are presented. As the estimated ground thermal conductivity differs by 10% between the two tests, possible sources of errors are examined in order to determine their influence on the response test results.

Local geology

Mengis + Lorenz AG (Keller, 2000) have made a model of the ground containing the future boreholes of the ground heat storage (see figure 1). The ground layer at the surface is

made of unconsolidated (quaternary) rocks. The boreholes will then cross 3 to 4 tilted ground layers. They are, from top to bottom, made of:

- fine to medium sandstones; upper freshwater molasse
- conglomerates and sandstones; upper marine molasse (St Galler formation)
- silt- and sandstones; upper marine molasse (St Galler formation)
- fine to medium sandstones; upper marine molasse (St Galler formation)

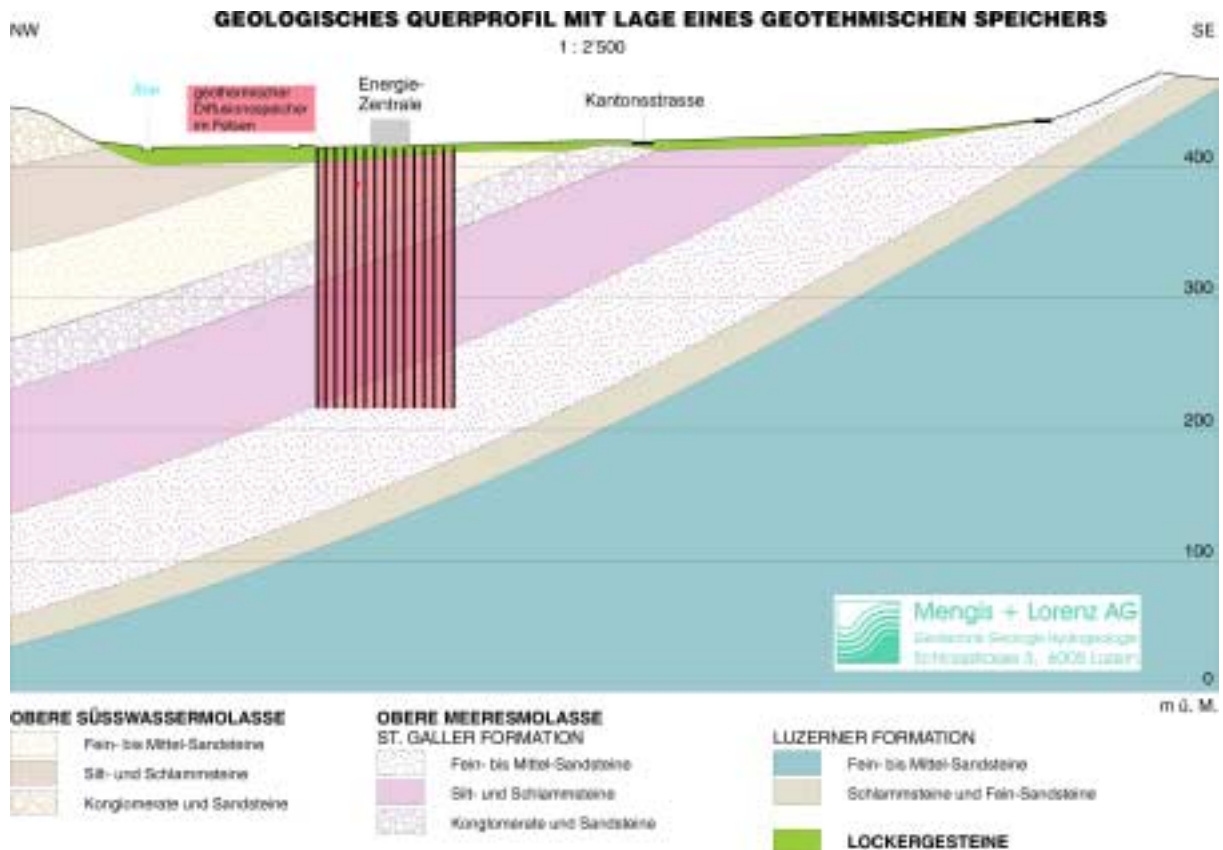

Fig. 1 Geological model of the ground at the site of the boreholes of the future ground heat storage (Keller, 2000).

Response test device

The response test device was developed in the LASEN / EPFL in the framework of a project related to the thermal solicitations of a heat exchanger pile (Laloui et al., 1998). The electric power can be set to 3, 6 or 9 kW. The pipes and the electric heater are carefully insulated.

The forward and return fluid temperature, the inside and outside air temperature, the fluid flow rate and the electric consumption (heater and pump) are measured and recorded every minute by a data logger to produce 10-minutes averages. The forward and return fluid temperatures are measured precisely in order to recalculate the thermal power injected into the borehole. A temperature difference accuracy of less than 0.05 K is expected with the following measurements:

- datalogger with an ADC (analogical to digital converter) of at least 16 bits;
- 1/5 DIN PT100 sensors;
- technique of the 4-wires PT100 measurement;
- calibration of the temperature difference in a constant temperature bath at various temperatures.

The flow rate is measured with an accuracy of 1% and the electric energy with an accuracy of 2%. A schematic drawing of the response test device is shown in figure 2.

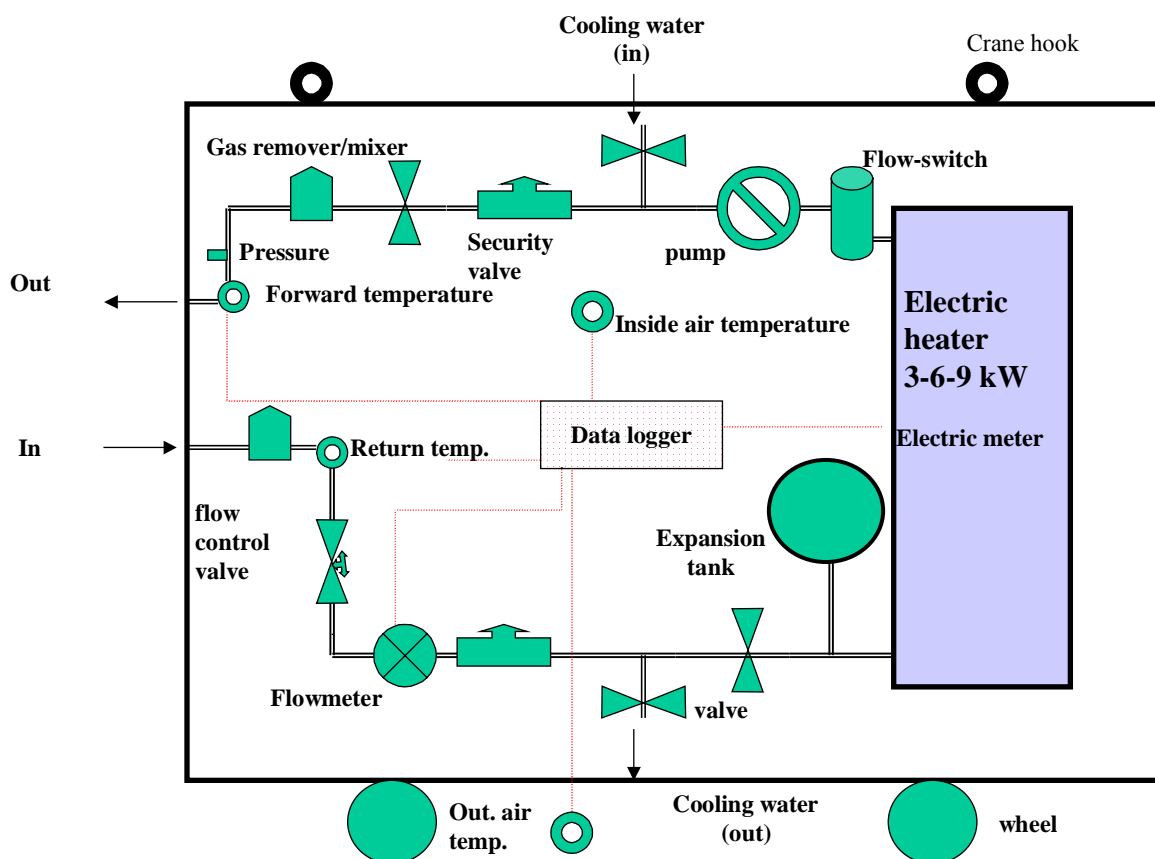

Fig. 2 Schematic view of the response test device.

Characteristics of the two boreholes

The two borehole heat exchangers are approximately 30 m apart. Halfway between them, a forage has been drilled to extract ground samples whose thermal properties were measured in a laboratory (Schärli and Rybach, 1999). The drilled boreholes were “dry”, in the sense that no ground water was coming out of the holes. The two U-pipes were fitted with spacers, and quartz sand was used instead of a mixture with bentonit for the filling material. The volume of sand was measured and corresponded to the volume to fill. The characteristics of the two boreholes are summarised in table 1. The flow rate during the test is rather low, mainly due to

the large pressure drop of the flow meter and the relatively small pump (electric consumption of about 60 W).

	North borehole	South borehole
Depth	160 m	162 m
Diameter	0.152 m	0.152 m
Pipe material	polyethylene	polyethylene
Outside pipe \varnothing	40 mm	40 mm
Pipe thickness	3.7 mm	3.7 mm
Nominal pressure	16 bar	16 bar
Spacers (shank spacing)	7.8 cm	7.8 cm
Filling material	quartz sand	quartz sand
Heat carrier fluid	water	water
Test flow rate	810 litre/h	810 litre/h

Table 1 Characteristics of the two boreholes.

Initial mean ground temperature

The initial ground temperature is measured in the north borehole. The temperature evolution of the inlet and outlet fluid temperature is shown in figure 3, before the heating is switched on.

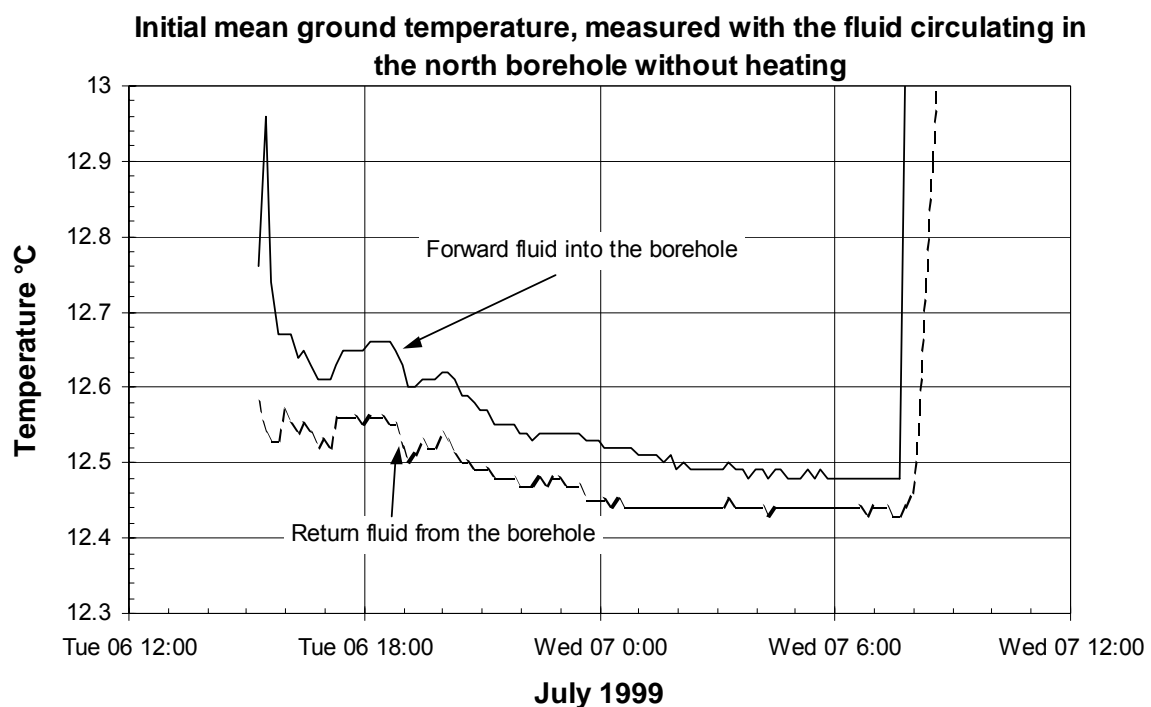

Fig. 3 Evolution of the fluid temperature in the north borehole before heating.

As the fluid in the response test device does not have the same temperature as the ground, time must elapse until the temperature stabilises. The 7th of July, measurements between 3 am and 7 am appear to be stable, mainly due to the outside air temperature which is also stable and close to the ground temperature (about 14 °C). During this period of time, the measured fluid temperature should be fairly close to the average ground temperature along the borehole. The influence of the pump heating effect should be lower than 55 W. With an expected borehole thermal resistance of 0.1 K/(W/m), it would result in a fluid temperature 0.03 K higher than the ground temperature. **The initial average ground temperature is estimated to 12.4 ± 0.1 °C.**

The north borehole response test

In figures 4 to 7, measurements from the north borehole are shown, together with the estimation of the ground thermal conductivity and the estimation of the effective borehole thermal resistance. The estimation of the thermal conductivity is based on the line source approximation (see Eskilson, 1987). In figure 4, the measured thermal power follows closely the measured electric power. It can be seen that the “constant” power of the electric heater exhibits variations which amount to about 5% of its average values. These variations are attributed to the grid voltage which varies during the day. They introduce a “noise” in the estimations of the ground thermal conductivity and the effective borehole resistance.

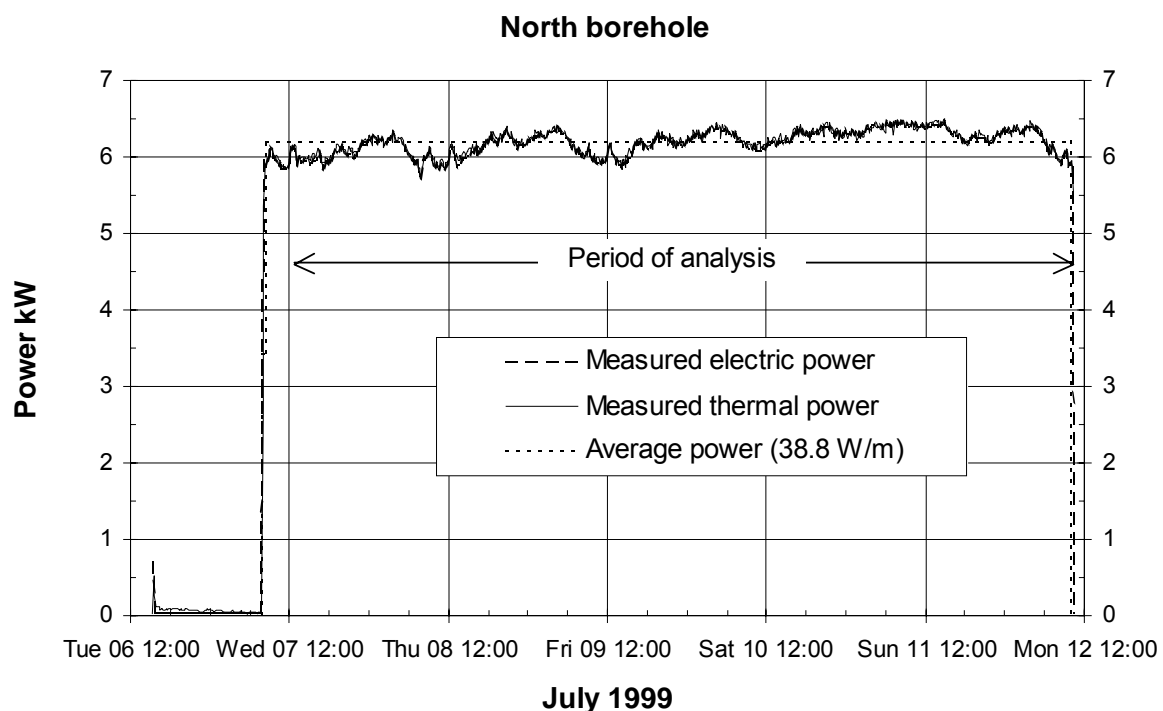

Fig. 4 Evolution of the injected thermal power in the north borehole.

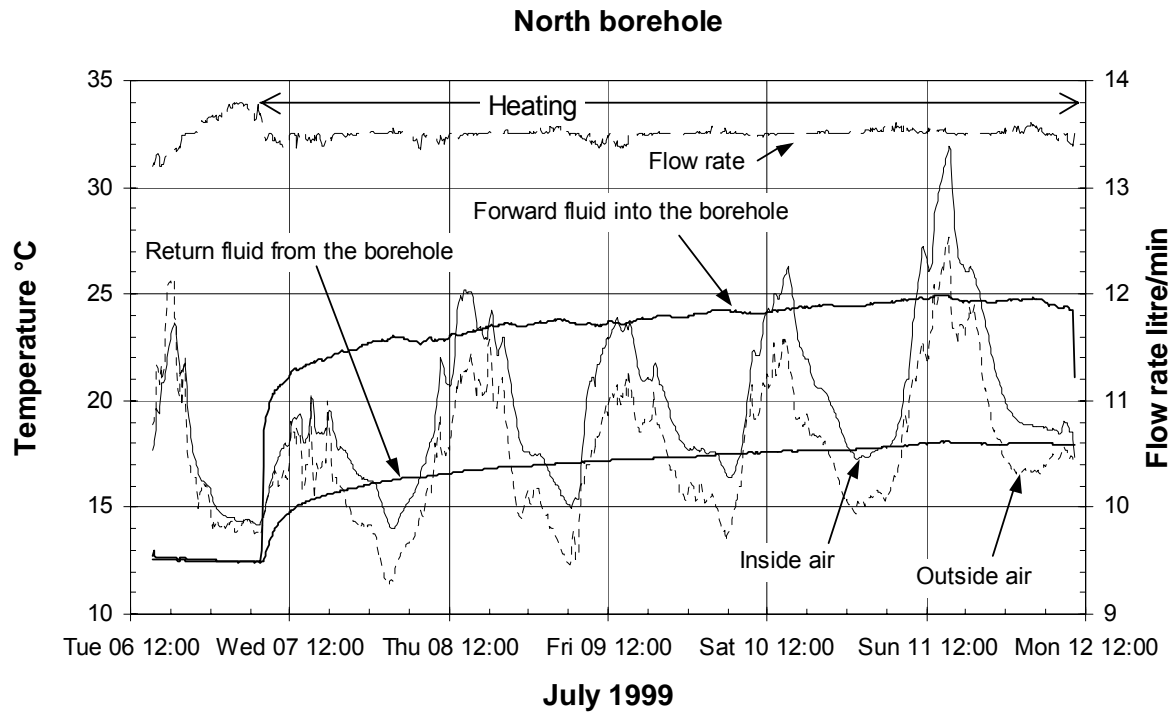

Fig. 5 Evolution of the measured temperatures and flow rate in the north borehole.

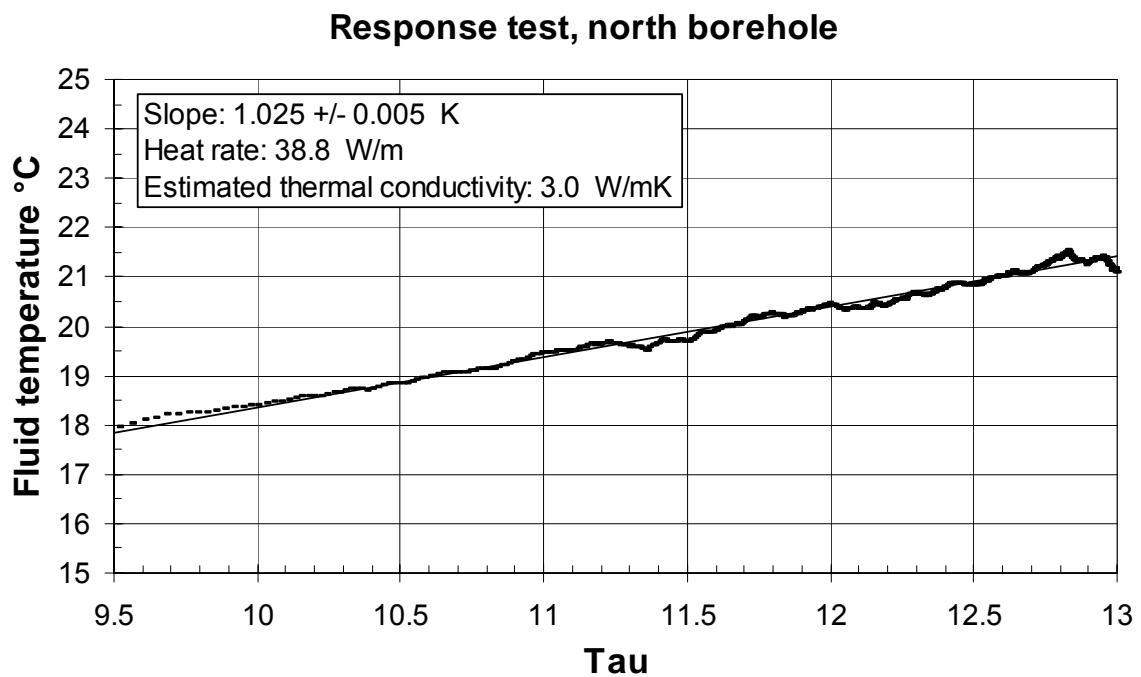

Fig. 6 Estimation of the thermal conductivity for the north borehole.

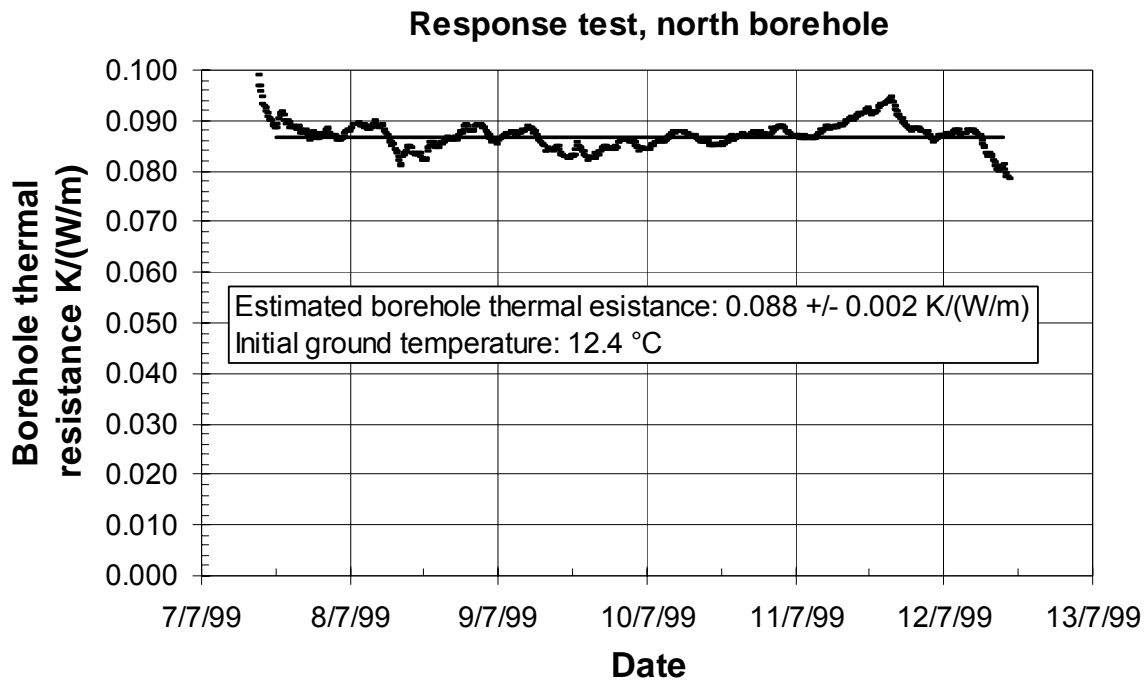

Fig. 7 Estimation of the effective borehole thermal resistance of the north borehole.

Results of the two response tests

Similar graphs are obtained with the south borehole. The results are summarised in table 2.

	North borehole	South borehole
Test duration	5 days	6.5 days
Ground thermal conductivity λ	3.0 W/mK	3.3 W/mK
Effective borehole resistance R_b^*	0.088 K/(W/m)	0.104 K/(W/m)

Initial ground temperature: 12.4°C
 Ground volumetric heat capacity: 2.1 MJ/m³K
 Thermal power during the test: ~ 40W/m

Table 2 Results of the two response tests.

The difference between the results of the north and south borehole is about 10%. The question is whether these differences can be explained by the errors. The error induced by each measured quantity or fixed parameter is given in table 3 for the north borehole. The elasticity is the relative influence of a parameter on the estimated value. For example, the thermal power has an elasticity of -1.2 on the borehole thermal resistance. In other terms, +1% error on the thermal power induces an estimation of the borehole thermal resistance 1.2% smaller.

North borehole ΔP or $\Delta P/P$	$\Delta\lambda$ W/mK	ΔR_b^* K/(W/m)
Thermal power: +5%	+0.15 (+1.0)	-0.005 (-1.2)
Bore length: +2m or ~1%	- 0.04 (- 1.0)	+0.001 (+1.3)
Bore diameter: +1cm or ~7%	-	+0.003 (+0.6)
Ground vol. heat cap. +10%	-	+0.002 (+0.3)
Initial ground temp.: +0.1K	-	-0.003
Temperature drift: +0.1K	+0.10	-0.002
Total (i.e. for R_b^* : $\sqrt{\sum \Delta R_b^* ^2}$)	± 0.18	± 0.007

The number given in brackets is the elasticity. This is for λ : $(\Delta\lambda/\lambda)/(\Delta P/P)$

Table 3 Errors induced by the measured quantities and the fixed parameters for the north borehole.

The total error amount to about 5%; similar results are obtained with the south borehole. However, the 10% difference between the north and south results can not be explained with these errors, as the most important ones would shift the results in the same direction (such as the error on the thermal power or the temperature drift). A temperature drift of 0.1 K during the test is also equivalent to a power drift of about 1 W/m. As shown below, it highlights the importance of having a stable heat injection rate during the test.

The test duration also has an influence on the results. It is illustrated with the values reported in table 4, which are estimated for different periods of time.

Test duration after time criterion met		North borehole	South borehole
2 days	λ	3.15 W/mK	3.41 W/mK
	R_b^*	0.093 K/(W/m)	0.111 K/(W/m)
3 days	λ	3.14 W/mK	3.44 W/mK
	R_b^*	0.092 K/(W/m)	0.111 K/(W/m)
4 days	λ	3.03 W/mK	3.53 W/mK
	R_b^*	0.088 K/(W/m)	0.112 K/(W/m)
5 days	λ	-	3.47 W/mK
	R_b^*	-	0.110 K/(W/m)
6 days	λ	-	3.32 W/mK
	R_b^*	-	0.106 K/(W/m)

The last evaluation day is a Sunday

Table 4 Estimation of the ground thermal conductivity and the effective borehole resistance using different periods of time.

The estimations are about 5% higher when the last day of the test is not taken into account. The last day is a Sunday for both cases. A closer look to the heating power reveals that it is

slightly higher during this day, due to the fact that the grid voltage, and thus the heating power, seem to be linked to industrial activity. However the 10% difference between the results of the two boreholes can not be explained with this effect.

Additional information

The EED programme (Hellström and Sanner, 2000) can be used to recalculate the effective borehole thermal resistance. The calculation parameters and calculated borehole thermal resistance are given in table 5.

Calculation parameters			Calculated resistances
Ground thermal conductivity	3.3	W/mK	Local borehole thermal resistance
Borehole installation	DOUBLE-U		
Borehole depth	160	m	0.065 K/(W/m)
Borehole diameter	0.152	m	
U-pipe diameter	0.04	m	Effective borehole thermal resistance
U-pipe thickness	0.0037	m	
U-pipe thermal conductivity	0.42	W/mK	
U-pipe shank spacing	0.087	m	
Filling thermal conductivity	1.5	W/mK	
Contact resistance pipe/filling	0	K/(W/m)	
Heat carrier fluid	water at 20°C		
Flow rate per borehole	0.000225	m ³ /s	0.109 K/(W/m)

Table 5 Calculation of the effective borehole thermal resistance with the EED programme.

Other available information is the laboratory measurements of the thermal conductivity made on the ground samples taken from the borehole drilled between the two borehole heat exchangers. The measured values are shown in figure 8 in relation to the depth (Schärli and Rybach, 1999). An average thermal conductivity of about **3.5 W/mK** can be visually estimated from the graph.

This additional information agrees with the results obtained with the south borehole, when Sunday is not used in the analysis of the response test. With the north borehole, the lower thermal conductivity seems to be compensated by a lower borehole thermal resistance. As the estimation of the borehole thermal resistance requires the estimated thermal conductivity value, a lower thermal resistance is obtained with a lower value of the thermal conductivity. In other terms, if the estimation of the thermal conductivity is influenced by an external phenomena (power drift due to heater or outside conditions), it also has an influence on the borehole thermal resistance in a way that tends to compensate for the thermal conductivity error. A borehole thermal resistance of 0.092 K/(W/m) is calculated with EED if the shank spacing and the filling thermal conductivity are respectively set to 11 cm and 4 W/mK, which are extreme values.

As the ground layers are tilted, these differences may also be caused by the actual ground thermal conductivity which may differ locally. Nevertheless this study has shown that the

stability of the heat power is an important factor during the test. It may vary on a daily basis, but the average daily value has to remain as constant as possible. We have seen that the heat power injected in the borehole depends on the grid voltage. Another important influence on the heat power are the outside conditions, i.e. the heat transfer between the atmosphere and the fluid through the equipment on ground surface. This aspect has not been studied in detail, although it may also have an influence on the estimation of the thermal conductivity.

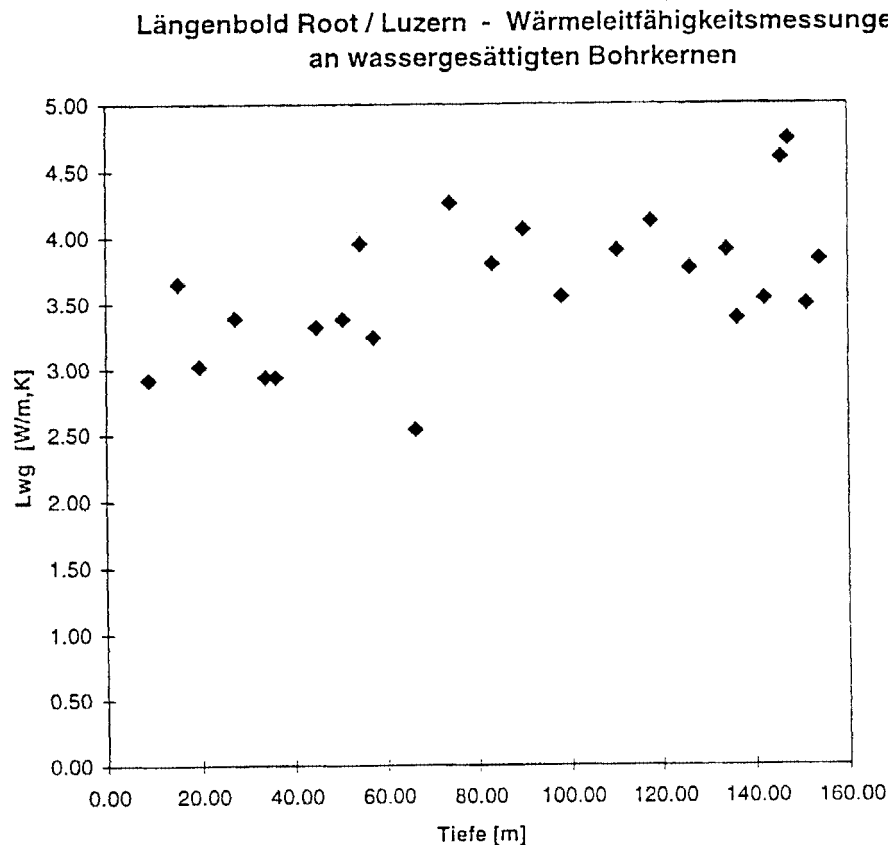

Fig. 8 Laboratory measurements of the ground samples taken in a borehole drilled between the north and south borehole heat exchangers (Schärli and Rybach, 1999).

Concluding remarks

The estimation of the ground thermal conductivity differs by 10% between the north and south borehole, although they are only spaced by 30 m. Measurement and parameter uncertainties can produce an error of 5%, but they can not explain the 10% difference, as they would shift the results mainly in the same direction. The stability of the heat injection rate is also an important criteria, at least on a daily basis. With the two response tests, the increase of the grid voltage on Sunday resulted in a 5% error on the estimated values. Here again, these variations can not explain the 10% difference, as they change the results in the same direction. Other possibilities are the outside conditions, which also influence the actual heat rate injected in the borehole, or the ground thermal conductivity, which may actually be different, as the

ground layers are tilted at this place. For both case, it means that the uncertainty on the ground thermal conductivity is about 10%.

To conclude, the design of a response test device should be performed in such a way that the influence of the outside conditions is as small as possible. For each test, the stability of the heat injection rate should be checked if not controlled when the line source approximation is used.

Acknowledgements

The Swiss Federal Office of Energy is acknowledged for its financial support.

References

- Eskilson P. (1987) Thermal Analysis of Heat Extraction Boreholes. Thesis. Department of Mathematical Physics, Lund Institute of Technology, Lund, Sweden.
- Hellström G., Sanner B. (2000): Earth Energy Designer, User's Manual, version 2.0 (<http://www.blocon.se/earth.htm>).
- Keller B. (2000) Mengis + Lorenz AG, private communications.
- Laloui L., Moreni M., Steinmann G., Fromentin A. and Pahud D. (1998) Test en conditions réelles du comportement statique d'un pieu soumis à des sollicitations thermo-mécaniques. Rapport intermédiaire de juillet 1998. Office fédéral de l'énergie, Bern, Switzerland.
- Pahud D. (1999) Etude pilote pour les bâtiments du centre SUVA Lucerne. Analyse des réponses de 2 sondes tests et optimisation du stockage diffusif. Rapport intermédiaire, Office fédéral de l'énergie, Berne, Suisse.
- Schärli U. und Rybach L. (1999) D4-Unternehmens- und Innovationszentrum Längenbold, Root (LU). Wärmeleitfähigkeits- und Wärmekapazitäts – Messungen an Bohrkernen (OMM). Interner Bericht Nr. 4321. Institut für Geophysik, Eidgenössische Technische Hochschule Zürich, Zürich, Schweiz.