



# Longitudinal study on the colonisation and transmission of methicillin-resistant *Staphylococcus aureus* in pig farms



Patrick Daniel Bangerter<sup>a</sup>, Xaver Sidler<sup>b</sup>, Vincent Perreten<sup>a</sup>, Gudrun Overesch<sup>a,\*</sup>

<sup>a</sup> Institute of Veterinary Bacteriology, Vetsuisse Faculty, University of Bern, Länggassstrasse 122, CH-3012 Bern, Switzerland

<sup>b</sup> Department of Farm Animals, Division of Swine Medicine, Vetsuisse Faculty, University of Zurich, Winterthurerstrasse 260, CH-8057 Zurich, Switzerland

## ARTICLE INFO

### Article history:

Received 26 June 2015

Received in revised form 7 December 2015

Accepted 10 December 2015

### Keywords:

LA-MRSA

Transportation

Slaughterhouse

Public health

Prevention

Swine

## ABSTRACT

Knowledge about the dynamics of methicillin-resistant *Staphylococcus aureus* (MRSA) in pigs lacks detail at the level of individual animal. The aim of our study was therefore to determine the colonisation status of MRSA in individual pigs from birth to slaughter in order to gain a better understanding of substantial factors involved in transmission. Two farrow-to-finish and two grow-to-finish herds were included in the study. A total of 1728 nasal swabs from 390 pigs and 592 environmental wipes were collected at 11 different time points.

Intermittent colonisation throughout the entire production cycle was conspicuous in the tracking of MRSA in individual pigs. Almost all pigs from a MRSA-positive herd changed MRSA status several times, which implies that pigs are transiently rather than permanently colonised. We highly recommend the definition of MRSA status at herd level rather than at the level of the individual pig when considering prevention measures against MRSA. Therefore, to avoid the further spread of MRSA in countries with moderate prevalence, such as in Switzerland, defining farms as MRSA positive or MRSA negative and allowing the trade of pigs only within herds of the same status seems feasible. This will also be important for combating the further dissemination of livestock-associated (LA)-MRSA into healthcare facilities and the community via humans who have close contact with animals.

© 2015 The Authors. Published by Elsevier B.V. This is an open access article under the CC BY-NC-ND license (<http://creativecommons.org/licenses/by-nc-nd/4.0/>).

## 1. Introduction

The rapid spread of LA-MRSA in pigs and farm animals worldwide has raised major public health concerns (Crombé et al., 2013; Verkade and Kluytmans, 2014; Voss et al., 2005). Colonised animals may act as a MRSA reservoir not only for livestock but also for humans with close contact to animals, i.e., farmers and veterinarians. As a consequence, higher colonisation rates and cases of infections have been reported in these professions at risk (Lewis et al., 2008; van Rijen et al., 2008; Wettstein Rosenkranz et al., 2014).

In 2009, official monitoring was launched for MRSA in pigs at slaughterhouses in Switzerland. The prevalence of MRSA in 2009 was very low at 2% (95% CI 0.9–3.9) but reached 20.8% (95% CI 16.7–25.45) in 2013 (Büttner et al., 2014; Overesch et al., 2012).

To date, little is known about the dynamics of MRSA in pigs because only a few longitudinal studies have been conducted. Those longitudinal studies that have been conducted examined the MRSA status in pigs mostly until slaughter age (Broens et al., 2012; Burns et al., 2014; Verheghe et al., 2013) or even just until the age of 70 days (Weese et al., 2011). Moreover, these studies did not provide results from individual pigs. Other studies examined only one MRSA-positive farm (Burns et al., 2014; Weese et al., 2011), and the results are unlikely to be generally applicable. Other researchers (Broens et al., 2011) considered the prevalence of MRSA before and after transportation of the pigs from farm to abattoir, but they did not examine the changes in the MRSA status of individual pigs at the farm while simply analysing pooled samples, from which individual changes could not be demonstrated. The dramatic increase of MRSA in Swiss slaughter pigs during recent years necessitates the introduction of measures to combat the further spread of MRSA in the Swiss pig population. However, until now, there have been no precise studies of the individual colonisation dynamics of MRSA throughout each pig production stage; these studies are needed to gain a better understanding of the substantial factors considering the prevention of the spread of MRSA and to identify targets for possible intervention measures.

\* Corresponding author. Fax: +41 31 6312634.

E-mail addresses: [patrick\\_bangerter@bluewin.ch](mailto:patrick_bangerter@bluewin.ch) (P.D. Bangerter), [xsidler@vetclinics.uzh.ch](mailto:xsidler@vetclinics.uzh.ch) (X. Sidler), [vincent.perreten@vetsuisse.unibe.ch](mailto:vincent.perreten@vetsuisse.unibe.ch) (V. Perreten), [gudrun.overesch@vetsuisse.unibe.ch](mailto:gudrun.overesch@vetsuisse.unibe.ch) (G. Overesch).

For that reason, we selected MRSA-positive and negative farms with different management practices, such as all in/all out and continuous animal flow systems and determined the MRSA status in the individual pig from birth throughout each production stage, up to and including transport and slaughtering.

## 2. Materials and methods

### 2.1. Farm characteristics and animals

Pigs from four Swiss pig farms were recurrently tested for the presence of MRSA between May and December 2014 during a production cycle of approximately 150–175 days, as well as additional pigs from three other farms on transportation to slaughterhouses. We chose two farrow-to-finish farms (ff-I, ff-II) as well as two grow-to-finish farms (gf-I, gf-II) for analysis, to determine if any variances between the different management systems exists. One farrow-to-finish farm was chosen as a MRSA-negative control farm whereas the other farrow-to-finish farm was MRSA-positive. Furthermore, one of the grow-to-finish farms was purchaser of grower pigs from a farrow-to-finish study-farm while the other grow-to-finish farm was not associated to any of the farms.

**Farm ff-I** consisted of 75 sows, 50 replacement gilts, two farrowing rooms for 18 sows in each room, one weaner accommodation and a finishing unit with a capacity for 200 fattening pigs. The farm had a three-week batch monitoring system. One cohort of ten pregnant sows approaching delivery was selected for starting sampling and placed after washing in a cleaned and disinfected farrowing room. Four sows were placed in pens with possible direct contact to the neighbouring pen through an open fence. The other six sows had no contact.

**Farm gf-I** purchased grower pigs from farm ff-I but also from other breeders. The farm had seven finishing pens with a capacity for 280 fattening pigs. One finishing pen containing 37 fattening pigs grown on farm ff-I was selected for sampling.

**Farm ff-II** consisted of 42 sows, one farrowing room with 12 farrowing pens, one weaner accommodation and a finishing unit with a capacity for 250 fattening pigs. Replacement gilts were purchased. The farm had no regular batch-monitoring system and routinely used post-weaning prophylactic feed supplementation with lincomycin and spectinomycin for three weeks. One cohort of three pregnant sows approaching delivery was selected for starting sampling. All three sows were placed in pens with possible direct contact to the neighbouring pen through an open fence. Five other pens were also occupied. The status of those sows was unknown.

**Farm gf-II** had one finishing pen with a capacity for approximately 90 fattening pigs. A total of 87 fattening pigs purchased from one breeder were selected for sampling.

More details of the farms are given in [Table 1](#). Samples and time points are listed in [Table 2](#).

### 2.2. Collection of samples

Nasal swabs from individual pigs were taken at the different time points during a production cycle up to and including slaughtering. When indicated, additional environmental wipes were also taken ([Table 2](#)). At the two farrow-to-finish farms (ff-I, ff-II), sows were sampled three times and their offspring nine times. At approximately four to five weeks of age, the piglets were merged into new groups. Each group was housed in a separate pen in one room in the weaner accommodation. At the age of nine to ten weeks at tp7, the grower pigs were merged into new groups and moved to first stage finishing. At tp8, at approximately 14 weeks of age, fattening pigs were moved to second stage finishing.

On the two grow-to-finish farms (gf-I, gf-II) grower pigs were purchased and housed in the finishing pens, where sampling began. They were sampled five times.

At the end of fattening, on all four farms (ff-I, ff-II, gf-I, gf-II), samples were taken at three different times, i.e., before (tp9i) and after (tp9ii) transportation and after stunning or bleeding (tp9iii). Slaughter pigs from the four farms were transported to three different commercial abattoirs (slaughterhouse sh-I, sh-II and sh-III), namely farm ff-I and gf-I to slaughterhouse sh-I, farm ff-II to slaughterhouse sh-II and farm gf-II to slaughterhouse sh-III. The lairages at slaughterhouse sh-I and sh-III were unused and clean, whereas the lairages at slaughterhouse sh-II had already been used earlier that day and were therefore not clean.

On transportation to the abattoir from farm ff-I, additional pigs ( $n = 42$ ) from one other farm were picked up by the same lorry. Initial nasal samples were taken from these pigs on the farm immediately before transportation (tp9i). During transport from farm gf-II, additional pigs from two other farms (farm 1,  $n = 56$ ; farm 2,  $n = 21$ ) also were picked up by the same lorry. Initial nasal samples from these pigs were taken on one day and two days before transport (tp9i). Additional pigs from the other farms were located in separate lorry sections, but contact between the pigs was possible. Moreover, for the transportation of batch ff-I and batch gf-I, 10 and 5 supplemental pigs, respectively, which were not part of the study, were transported and tested as well but only at tp9i, 9ii and 9iii.

Nasal samples were collected using transport swabs (Transwab<sup>®</sup> Amies MW172, MWE Medical Wire, Corsham, England and Uni-Ter Amies CLR, Meus S.r.l., Piove Di Sacco, Italy) from both nares of the pigs. Environmental wipes (lair, wall, watering place, manger and steel parts) were collected from the farrowing pens, the weaner accommodation, the fattening units and the lairages at the slaughterhouse, as well as from the lorries, using wipes (Triko-Tex<sup>®</sup> 18 × 32 cm, Chicopee Europe, Katwijk, The Netherlands) moistened with distilled water. Samples were taken by wiping the surface of the steel parts, each part with one wipe, and the wall at the height of the snout. In each box, one wall was selected for sampling. Each wipe was individually placed in a sterile Stomacher bag. Depending on the transfer or death of the pigs, the number of

**Table 1**  
Characteristics of the farms.

Farm no	MRSA status <sup>a</sup>	Operation type	Other livestock on farm	Antimicrobial group treatment <sup>b</sup>
ff-I	Positive	Farrow- to-finish farm Continuous flow	No	No
gf-I	Positive	Grow-to-finish farm Continuous flow	Yes (calves)	No
ff-II	Negative	Farrow-to-finish farm Continuous flow	No	Yes
gf-II	Positive	Grow-to-finish farm All in–all out flow	Yes (dairy cows)	No

<sup>a</sup>According to previous screening.

<sup>b</sup>During the production cycle.

**Table 2**

Time points of sampling, type of sample, age group and age of the pigs, sampled compartment and farm on which samples were taken.

Time point	Type of sample	Age group	Age	Sampled compartment	Farm
1	Nasal	Sows	1 week prior to farrowing	Farrowing <sup>a</sup>	ff-I, ff-II
	Environment				ff-I, ff-II
2	Nasal	Piglets/Sows	Within 24 h post-natal		ff-I, ff-II
3	Nasal	Piglets	5–14 days		ff-I, ff-II
4	Nasal	Weaned piglets/Sows	24–38 days	Farrowing <sup>b</sup> /Weaning <sup>a</sup>	ff-I, ff-II
	Environment				ff-I, ff-II
5	Environment <sup>c</sup>			Farrowing <sup>a</sup>	ff-I
6	Nasal	Weaned piglets	5–7 weeks		ff-I, ff-II
7	Nasal	Growers	8–11 weeks	Weaning <sup>b</sup>	ff-I, ff-II, gf-I, gf-II
	Environment				ff-I, ff-II
8	Nasal	Finishers	15–19 weeks	Fattening <sup>a</sup>	ff-I, ff-II, gf-I, gf-II
	Environment			ff-I, ff-II, gf-I, gf-II	
9 i	Nasal	Finishers	21–25 weeks	Fattening <sup>b</sup>	ff-I, ff-II, gf-I, gf-II
	Environment			ff-I, ff-II	
9 ii	Nasal	Finishers	21–25 weeks	Finishing <sup>a</sup>	ff-I, ff-II, gf-I, gf-II
	Environment			ff-I, ff-II	
9 iii	Nasal	Finishers	21–25 weeks	Lorry <sup>a</sup> /Abattoir <sup>a</sup>	ff-I, ff-II, gf-I, gf-II
	Environment			ff-I, gf-I	
	Nasal			Lorry <sup>b</sup>	ff-I, ff-II, gf-I, gf-II
	Environment			Abattoir <sup>b</sup>	ff-I, ff-II, gf-I, gf-II

<sup>a</sup> Before use.<sup>b</sup> After use.<sup>c</sup> Environmental wipes from the same farrowing pens, two days after weaning afterwards cleaning and disinfection.

sampled pigs varied over time. 144 pigs were not tested throughout the complete period of the study for different reasons like death, slaughtered later, used for breeding. Details for individual exclusion are given in Figs. 1–6.

### 2.3. Sample processing for MRSA isolation

Samples were transported within three hours at ambient temperature to the laboratory, with the exception of nasal swabs from farm ff-1 at tp2. Samples from new-born piglets were collected at 5 °C for a maximum of six days and afterwards transported under cooled conditions (< 12 °C) to the laboratory. After delivery, swabs were transferred into tubes containing 10 ml Mueller Hinton Broth supplemented with 6.5% NaCl. A total of 50 ml Mueller Hinton Broth supplemented with 6.5% NaCl was added to each Stomacher bag containing environmental wipes and homogenised in a Stomacher<sup>®</sup> 400 circulator (Seward Ltd., UK) for 15 s at 230 RPM. The samples were incubated aerobically at 37 °C for 24 h while being shaken. One ml from each pre-enrichment was inoculated into 9 ml tryptone soy broth containing 3.5 mg/l cefoxitin and 75 mg/l aztreonam, and further incubated aerobically at 37 °C for 24 h. Ten microliters was then spread onto MRSA selective agar plates (BBL™ CHROMagar™ MRSA; Becton Dickinson, Franklin Lakes, NJ, USA), which were incubated at 37 °C for 24 h. Pink to mauve-coloured colonies were regarded as suspicious, and one presumptive colony from each plate was cultivated onto tryptone soy agar plates containing 5% sheep blood (TSA-SB) (Oxoid Ltd, Basingstoke, England) at 37 °C for 24 h. *S. aureus* was identified by matrix-assisted laser desorption/ionisation time-of-flight mass spectroscopy (MALDI TOF MS) (Biotyper 3.0, Bruker) using the direct transfer protocol recommended by the manufacturer. The identification of all MRSA isolates was confirmed by PCR targeting the *mecA* gene, which encodes for methicillin-resistance (Stegger et al., 2011). Positive (*S. aureus* MRSA K/M1474/08 laboratory collection) and negative (*S. aureus* ATCC 25923) control strains were included. The obtained MRSA isolates were subsequently stored at –80 °C in trypticase soy broth supplemented with 30% glycerol for further examination.

### 2.4. Statistical methods

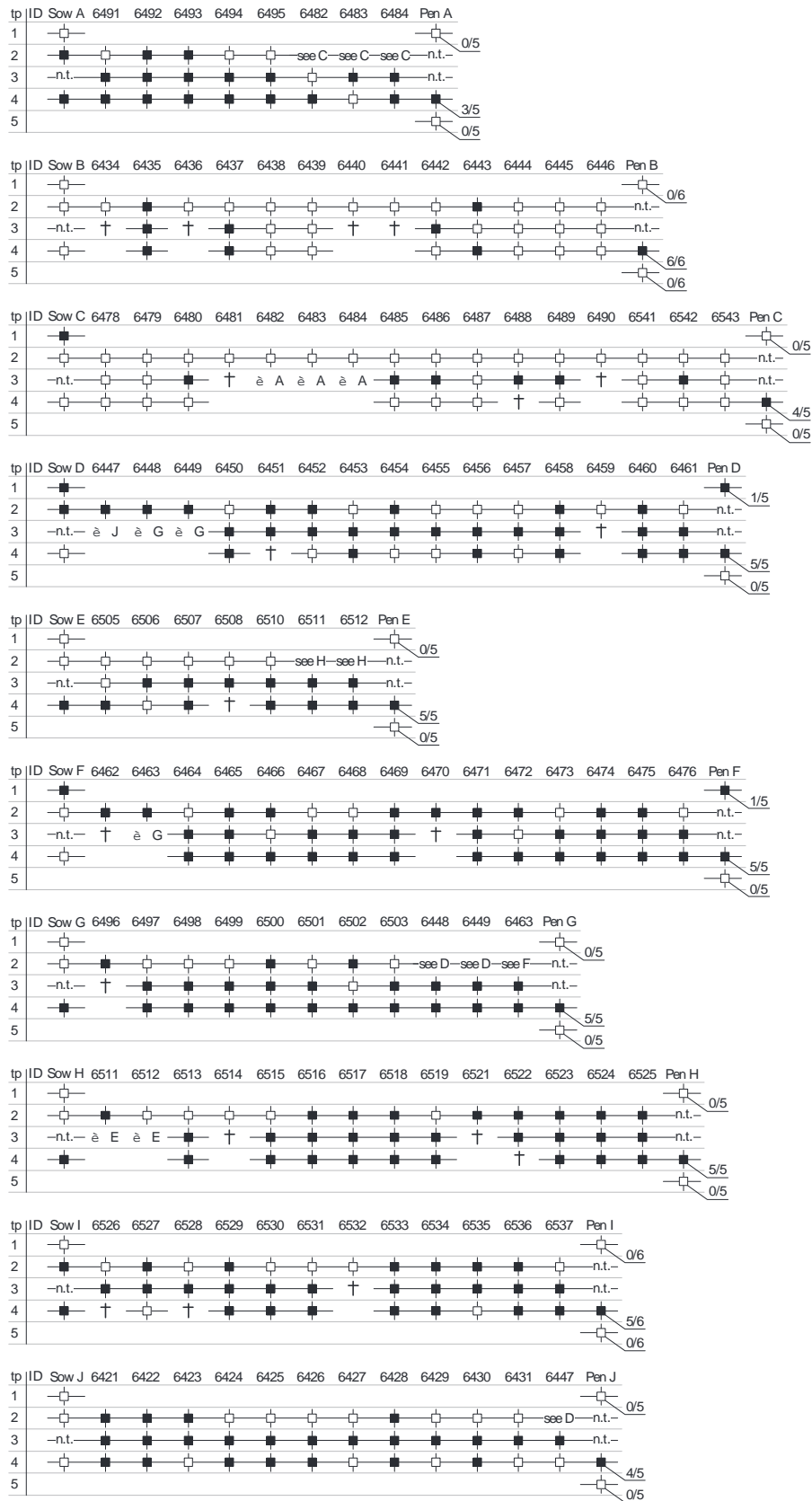
Prevalences in the text were calculated on the number of MRSA positive pigs based on the total number of pigs at the particular time point. Rates of changes in the text and Table 3 were calculated as number of changes from MRSA negative to positive based on pigs that were negative at the first time point and from MRSA positive to negative based on MRSA positive pigs at the respective time point. At last, rates of pigs without change of the MRSA status based on the total number of pigs at the first time point were calculated. Values are given in percent. All statistics were performed using the NCSS 10 statistical software (2015, NCSS, LLC. Kaysville, Utah, USA, [ncss.com/software/ncss](http://ncss.com/software/ncss)).

### 3. Results

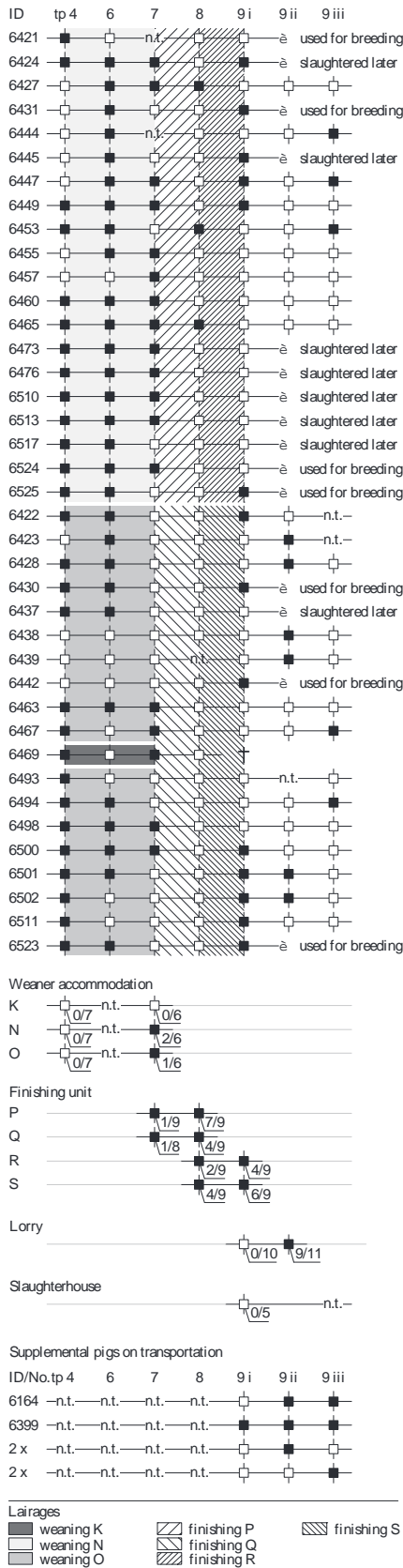
In total, 1728 nasal swabs from 390 pigs and 592 environmental wipes were collected from the four studied farms, as well as from three additional farms from which samples were taken only in pigs being transported. Individual results of the animal and environmental samples are summarised in Figs. 1–6. Moreover, Table 3 shows the percentage changes of the MRSA status of the pigs for every transition from one time point to another for every farm.

On farm ff-I, of ten sows (A–J) sampled before farrowing at tp1, three were MRSA positive (sows C, D and F) and seven were MRSA negative (sows A, B, E, G, H, I and J) (Fig. 1). Of the three MRSA-positive sows, two (sows C and F) had showed changed MRSA status 24 h after birth (tp2) to negative and stayed negative until the piglets were weaned at approximately 28 days (tp4). Only two sows (sows B and J) were screened as negative at all three sampling moments. After up to ten days of life (tp3), the majority of the piglets tested MRSA positive, i.e., 84.2% (85/101), as a consequence of high percentage changes of the MRSA status from tp2 to tp3 (80.3%) (Table 3).

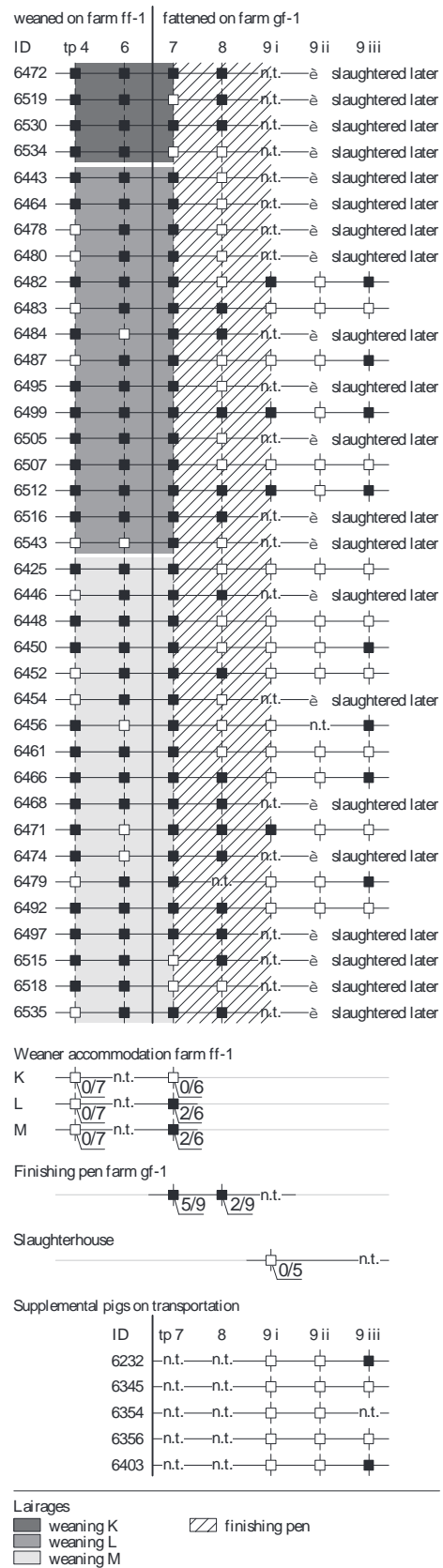
After weaning, the environmental wipes from the pens were almost all MRSA positive, whereas wipes, after the farrowing pens had been cleaned, were all negative.



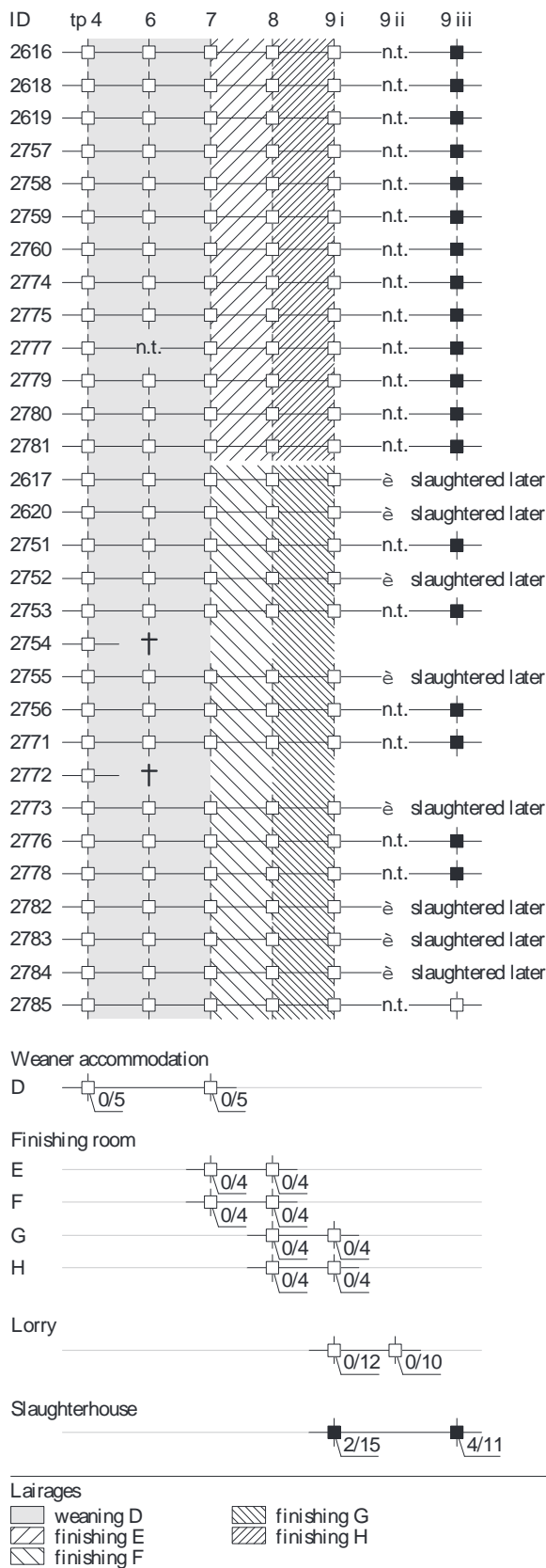
**Fig. 1.** MRSA status of sows and offspring on farm ff-l. & , MRSA-negative; ■, MRSA-positive; †, deceased; →, piglet moved; ID, ear tag; tp, time point; n.t., not tested; 2/15, environmental samples (n positive/N total).



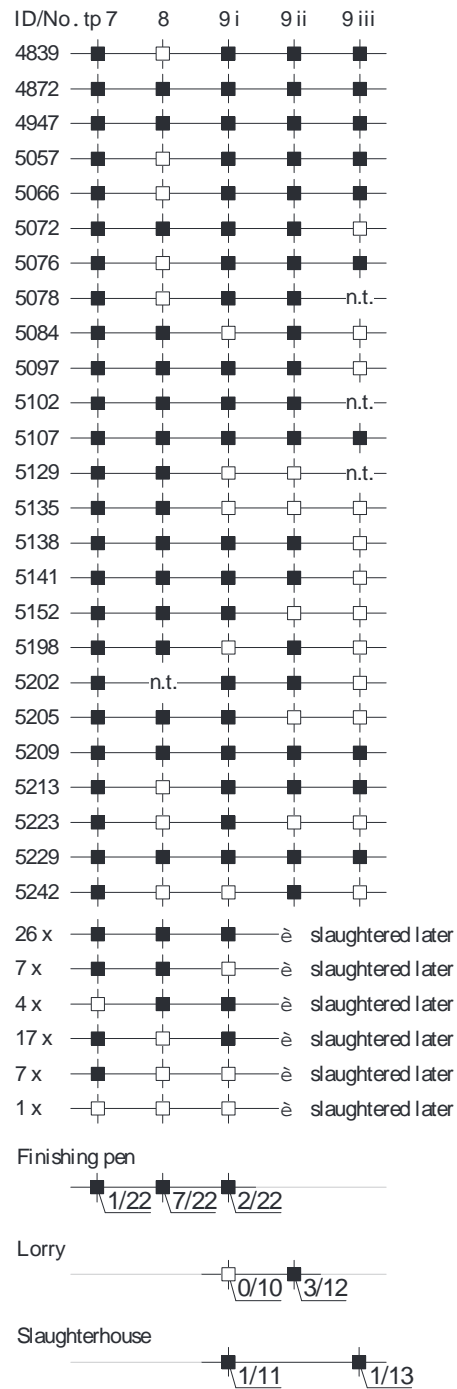
**Fig. 2.** Fattening pigs weaned and fattened on farm ff-1. 6164–6399, supplemental fattening pigs from farm ff-1 which were not part of the study, sampled at tp 9 only. &, MRSA-negative; ■, MRSA-positive; †, deceased; ID, ear tag; tp, time point; n.t., not tested; 2/15, environmental samples (n positive/N total).



**Fig. 3.** Fattening pigs weaned on farm ff-1 and purchased for fattening to farm gf-1. 6232–6403, supplemental fattening pigs from farm gf-1 which were purchased from the same breeder (ff-1) but not part of the study. Sampled at tp 9 only. &, MRSA-negative; ■, MRSA-positive; ID, ear tag; tp, time point; n.t., not tested; 2/15, environmental samples (n positive/N total).

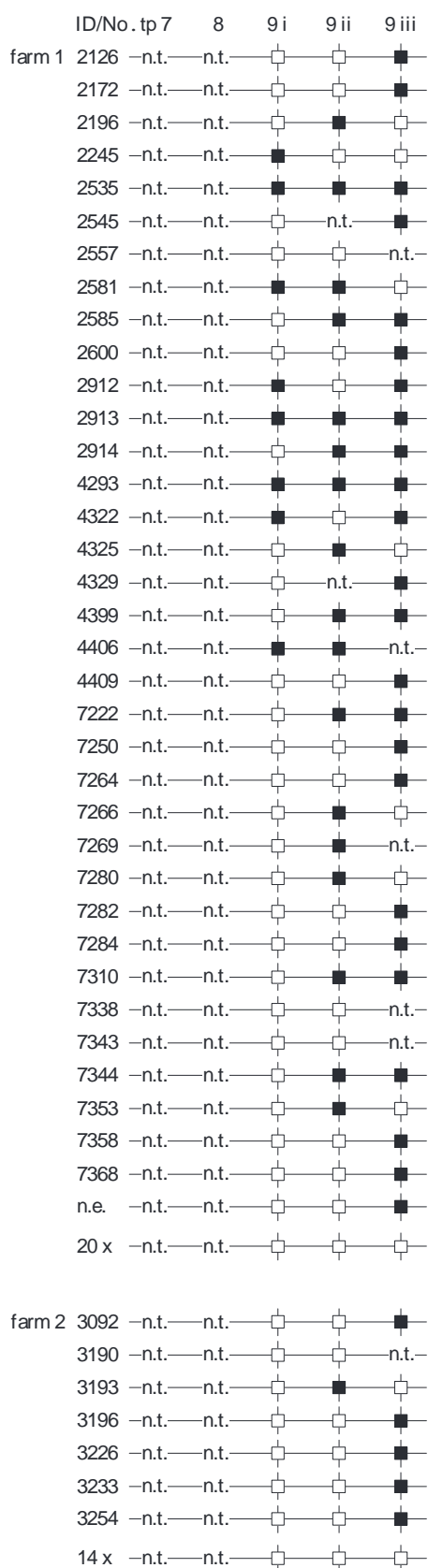


**Fig. 4.** Fattening pigs on farm ff-II. & , MRSA-negative; ■, MRSA-positive; †, deceased. ID, ear tag; tp, time point; n.t., not tested; 2/15, environmental samples (*n* positive/*N* total).



**Fig. 5.** Fattening pigs on farm gf-II. & , MRSA-negative; ■, MRSA-positive. ID, ear tag; No., number of pigs with the same result; tp, time point; n.t., not tested; 2/15, environmental samples (*n* positive/*N* total).

At approximately 28 days of age (tp4), pigs (*n* = 95) were merged in weaner groups K, L, M, N and O and penned in the weaner accommodation (Figs. 2 and 3). Thirty-one of the weaned pigs that were sampled 3 times at the weaner accommodation (tp4, 6 and 7) remained MRSA positive at all tp sampled (41.9%; 31/74), but all other pigs (54.1%; 40/74) changed their MRSA status once or even twice. The prevalence at tp4 (before rehousing), 6 and 7 was 69.5% (66/95), 80.3% (61/76) and 68.9% (51/74), respectively. Environmental wipes from the weaner accommodation were all MRSA negative previous to penning, whereas after holding pigs, nearly all pens tested MRSA positive (Figs. 2 and 3).



**Fig. 6.** Slaughter pigs of two other farms on the transport batch gf-II, sampled at tp 9 only.

□, MRSA-negative; ■, MRSA-positive.

ID, ear tag; No., number of pigs with the same result; tp, time point; n.t., not tested; n.e., no ear tag; 2/15, environmental samples (*n* positive/*N* total).

At the end of finishing, the MRSA status of the individual pigs was intermittent during the entire fattening cycle (Fig. 2). The prevalence at tp8 and 9i was 7.9% (3/38) and 36.8% (14/38), respectively, and therefore was much lower than at earlier time points. In parallel, high percentage changes (94.1%) from a MRSA positive to MRSA negative status was observed from tp7 to tp8 (Table 3). Even after transportation (tp9ii) and after stunning (tp9iii), the individual MRSA status of a pig could have changed (Fig. 2). Only seven pigs (35.0%; 7/20) that tested MRSA negative at tp9i and 9ii remained negative even after stunning (tp9iii). Ten supplemental pigs were finished and slaughtered together with the study pigs but only tested at the end of fattening at tp9 immediately before transportation (Fig. 2). Only one pig was MRSA positive at tp9i; however, another four were positive at tp9iii, and two had changed from MRSA positive after transportation (tp9ii) to negative after stunning (tp9iii). Slaughter pigs (*n* = 42) from one other farm were transported on the same lorry to the abattoir and also tested at tp9 at the end of fattening (data not shown). In three of these animals, the intermittent MRSA status can also be seen, i.e., changing from MRSA negative at tp9i and 9ii to positive after stunning (tp9iii). Environmental wipes taken from the lorry previous to transportation were all MRSA negative, whereas nearly all samples after transport of the pigs were MRSA positive. Environmental wipes taken from the unused lairages at slaughterhouse were all MRSA negative (Fig. 2).

On **farm gf-I**, thirty-seven grower pigs out of three weaner groups (K, L and M) from farm ff-I were purchased with approximately eight weeks and penned together for fattening (Fig. 3). Sixteen pigs were tested until tp9iii, whereas another 21 pigs were only tested at tp7 and tp8, because they were slaughtered later. The MRSA status of individual pigs was intermittent during the entire fattening cycle. This also can be shown by the percentage changes of the MRSA status of the pigs, which were comparable to the data of farm ff-I (Table 3). In general the prevalence was decreasing, i.e., 50.0% (18/36) at tp8 and 25% (4/16) at tp9i. Environmental wipes from the finishing pen were MRSA positive previous to penning (tp7), as well as in the middle of the fattening cycle (tp8).

Even after transportation (tp9ii) and after stunning (tp9iii), the MRSA status of individual pigs had changed (Fig. 3). Five supplemental pigs were finished at farm gf-I and slaughtered together with the study pigs but only tested at the end of fattening at tp9. All pigs were MRSA negative at tp9i and 9ii. Interestingly, two pigs became MRSA positive at tp9iii after stunning. Environmental wipes taken from the unused lairages at slaughterhouse were all MRSA negative (Fig. 3).

On **farm ff-II**, all three sows (sows A, B and C) sampled before farrowing at tp1 were MRSA negative, as were the environmental wipes from the farrowing pens prior to holding pigs (data not shown). None of the three sows changed their MRSA status until the piglets were weaned (tp4) at approximately 35 days of age. At 24 h after farrowing (tp2), the offspring (*n* = 39) were completely negative. Also, the environmental wipes from the farrowing pens after holding pigs were MRSA negative (Fig. 4).

All weaned pigs stayed MRSA negative at all tp sampled (tp4, 6 and 7) throughout weaning. The MRSA status was consistently MRSA negative until tp9i, but changed to MRSA positive after stunning (tp9iii) in all but one animal. The percentage changes from a MRSA negative to MRSA positive status at tp9ii to tp9iii was thereby 95% (Table 3). Environmental wipes from the pens at the finishing room and from the lorry after transportation were consistently MRSA negative. In contrast environmental wipes from the lairages at the slaughterhouse were MRSA positive before, as well as after, holding pigs (Fig. 4).

On **farm gf-II**, eighty-seven grower pigs were merged together at approximately ten weeks (tp7) in one group and used for

**Table 3**  
Rates of changes of the MRSA status of the pigs for every transition from one time point to another.

	tp2–3			tp3–4			tp4–6 <sup>a</sup>			tp6–7		
	% n–p	% p–n	% n.ch.	% n–p	% p–n	% n.ch.	% n–p	% p–n	% n.ch.	% n–p	% p–n	% n.ch.
<b>Farm ff-I</b> (95% CI)	80.3 (68.2– 89.4)	10.2 (2.9– 24.2)	47.0 (36.9–57.2)	37.5 (1.5– 64.6)	24.1 (15.1– 35.0)	73.7 (63.6–82.2)	63.6 (30.8– 89.1)	21.4 (8.3– 41.0)	66.7 (49.8–80.9)	33.3 (7.5–70.1)	46.4 (27.5– 66.1)	56.8 (39.5–72.9)
<b>Farm ff-II</b> (95% CI)	0.0 (0.0–11.2)	n.c. <sup>b</sup>	100.0 (88.8– 100.0)	0.0 (0.0– 11.6)	n.c.	100 (88.4– 100.0)	0.0 (0.0–12.8)	n.c.	100.0 (87.2– 100.0)	0.0 (0.0–12.8)	n.c.	100.0 (87.2– 100.0)
<b>Farm gf-I</b> (95% CI)	– <sup>c</sup>	–	–	–	–	–	90.9 (55.5– 99.8)	14.8 (4.2– 33.7)	64.9 (47.5–79.8)	100.0 (4.8– 100.0)	12.5 (3.5–29.0)	75.7 (58.8–88.2)
	tp7–8			tp8–9i			tp9i–9ii			tp9ii–9iii		
	% n–p	% p–n	% n.ch.	% n–p	% p–n	% n.ch.	% n–p	% p–n	% n.ch.	% n–p	% p–n	% n.ch.
<b>Farm ff-I</b> (95% CI)	5.3 (0.1– 26.0)	94.1 (71.3– 99.9)	50 (32.9– 67.1)	41.2 (24.6– 59.3)	100 (29.2– 100.0)	54.1 (36.9– 70.5)	26.7 (7.8– 55.1)	71.4 (29.0– 96.3)	59.1 (36.4– 79.3)	33.3 (11.8– 61.6)	100 (47.8– 100.0)	50 (27.2– 72.8)
<b>Farm ff-II</b> (95% CI)	0.0 (0.0– 12.3)	n.c.	100.0 (87.7– 100.0)	0.0 (0.0– 12.3)	n.c.	100.0 (87.7– 100.0)	n.t.	n.t.	n.t.	95.0 <sup>d</sup> (75.1– 99.9)	n.c.	5.0 <sup>d</sup> (0.1– 24.9)
<b>Farm gf-I</b> (95% CI)	50 (6.8– 93.2)	50 (31.9– 68.1)	50 (32.9– 67.0)	12.5 (3.2– 52.7)	57.1 (18.4– 90.1)	66.7 (38.4– 88.2)	0.0 (0.0– 28.5)	100.0 (39.8– 100.0)	73.3 (44.9– 92.2)	46.7 (21.2– 73.4)	n.c.	53.3
<b>Farm gf-II</b> (95% CI)	80.0 (28.4– 99.5)	39.5 (28.8– 51.0)	58.1 (47.0– 68.7)	72.7 (54.5– 86.7)	20.8 (10.8– 34.1)	59.3 (48.2– 69.8)	60 (14.7– 94.7)	15 (3.2– 37.9)	76.0 (54.9– 90.6)	0.0 (0.0– 60.2)	44.4 (21.5– 69.2)	63.4 (40.7– 82.8)

tp: time point, n–p: change from MRSA negative to positive, p–n: change from MRSA positive to negative, n.ch.: no change, n.t.: not tested, CI: confidence intervals.

<sup>a</sup> Time point 5 has been omitted because only environmental wipes were taken.

<sup>b</sup> n. c.: not calculated, changes cannot be calculated as there are no positive pigs.

<sup>c</sup> At time point 2, 3, 4 and 6, the piglets/weaned pigs were still housed on farm ff-I. Results were included in the results from farm ff-I. From transition tp4 to tp6 on, results were displayed at farm gf-I.

<sup>d</sup> At time point 9ii, it was not possible taking nasal swabs at the slaughterhouse, therefore the results refer to the transition from time point 9i to 9iii.

fattening (Fig. 5). The MRSA status of individual pigs was intermittent during the entire fattening cycle. In general, the prevalence decreased at the beginning of fattening (tp7 and 8) but slightly increased towards the end of fattening (tp9i), i.e., 94.3% (82/87), 61.6% (53/86) and 77.0% (67/87), respectively. Environmental wipes from the finishing pen were MRSA positive, before penning, as well as after holding pigs (Fig. 5). Also after transportation (tp9ii) and after stunning (tp9iii), the MRSA status of pigs had changed (Fig. 5). Fig. 6 shows results from additional slaughter pigs from two other farms; these pigs were transported on the same lorry as the study pigs from farm gf-II to the abattoir. In the majority of the pigs, intermittent MRSA status can be seen (Fig. 6). The overall dynamics of percentage changes of the MRSA status was shown to be comparable to farm ff-I and farm gf-I (Table 3). Environmental wipes taken from the lorry prior to transporting the pigs were all MRSA negative, whereas nearly one-third of the samples after transporting the pigs were MRSA positive. Environmental wipes from the lairages at the slaughterhouse were MRSA positive before as well as after holding pigs (Fig. 5).

#### 4. Discussion

The present study investigated the transmission of MRSA among individual pigs within a herd from birth to slaughter and between herds at transportation and slaughter. A better understanding of the critical points that are potentially responsible for both the spread and persistence of MRSA has been achieved.

The majority of all pigs from a MRSA-positive herd changed the MRSA status throughout the entire production cycle at least two times (Figs. 1–3 and Fig. 5). The prevalence varied widely from 7.9%

to 94.3% throughout the observation period. Varying prevalence has also been demonstrated in various other studies (Burns et al., 2014; Dewaele et al., 2011; Weese et al., 2011).

At farm ff-I the highest percentage change from a MRSA negative to MRSA positive status was seen within piglets less than fourteen days of age, whereas changes from MRSA positive to MRSA negative were highest at the beginning of the fattening period (Table 3). Intermittent MRSA colonisation in individuals, as shown in the current survey, implies that pigs are transiently rather than permanently colonised. Little is known about the mechanisms that are responsible for such conditions. In humans, persistent colonisation occurs only in 20% of cases, 60% are intermittent carriers, and 20% are non-carriers (Wertheim et al., 2005; Williams, 1963). Persistent carriers are frequently colonised by a single strain of *S. aureus*, and the load is higher (Eriksen et al., 1995; Nouwen et al., 2005, 2004b; VandenBergh et al., 1999). The MRSA status in farmers versus humans without regular contact to livestock has been investigated in other studies (Köck et al., 2012; Van Cleef et al., 2011). The results of Van Cleef et al. (2011) indicated that short-term exposure of humans on MRSA-positive farms frequently results in the acquisition of MRSA, but the majority of persons lose the MRSA strain within 24 h. They stated that the high prevalence of MRSA carriage in farmers and veterinarians could partly be the result of repeated contamination instead of real persistent colonisation. Köck et al. (2012) showed that 45.7% of farmers were persistently colonised with LA-MRSA, even over periods of non exposure. But 54.3% of the farmers turned out to be non-carriers or intermittent carriers. This situation may also be true for pigs, as the intermittent colonisation might point to a repeated contamination in a MRSA-positive environment as described above. Host characteristics and an optimal balance

between the forces of defence and attraction seem to be responsible for the *S. aureus* carrier state (Nouwen et al., 2004a). Further studies are needed to investigate the underlying factors of MRSA contamination versus colonisation in pigs. Two time points are of major interest for such further investigations; piglets, which changed frequently from a MRSA negative to MRSA positive status within the first fourteen days of life and on the other hand grower pigs, often became MRSA negative at the beginning of the fattening period.

Transportation and processes at the slaughterhouse turned out to be critical control points for the spread of MRSA. At farm ff-II all pigs tested MRSA negative throughout the entire production cycle, but tested MRSA positive after stunning (Fig. 4). We also observed that pigs from another farm, tested MRSA negative prior to transport, but tested MRSA positive after transportation on a lorry with MRSA-positive pigs (Fig. 6). These findings are in agreement with other studies (Broens et al., 2011; de Neeling et al., 2007). The most probable sources of MRSA are lorries, lairages and/or contact to other pigs, either transported together on the same lorry or in contact at slaughterhouse. Our findings support this assumption, as environmental wipes taken from lairages at slaughterhouse sh-II were MRSA positive before and after MRSA-negative pigs were housed there. As a consequence, all but one pig (19/20) that were held in this MRSA-positive lairage changed MRSA status from negative to positive after stunning. In the same slaughterhouse, the probability of MRSA transmission from the environment to the pigs is further increased by the fact that pigs are kept at least two hours at the lairage prior to slaughter. To avoid the transmission of MRSA from the lairages to slaughter pigs, a strict hygiene management is required, such as cleaning lairages for every new slaughter batch and avoiding long resting times in lairages before slaughtering. Successful cleaning is feasible since environmental wipes from other slaughterhouses were tested MRSA negative in our study. Possibly, MRSA transmission from pig to pig may be minimised if contact between pigs on lorries or at slaughterhouse is strictly impossible, e.g., using completely closed fences. Another possibility could be to transport only MRSA-negative pigs instead of mixing pigs with unknown MRSA status.

The necessity for defining a MRSA status at the herd level instead of the level at the individual pig is clearly demonstrated in our study. The determination of the MRSA status of an individual pig reflects only a short moment in life. Because this status can change immediately, the separation within a herd of MRSA-positive from MRSA-negative pigs as a basis for subsequent eradication is not possible. In contrast, defining MRSA-positive and negative farms by screening batches of individual pigs and/or the environment was shown to be very reliable. Therefore, defining farms either as MRSA positive or negative and limiting animal trade to herds of the same status is highly recommended, when the spread of MRSA should be prevented. Our results demonstrated that it is essential for MRSA-negative farms to purchase pigs only from breeders that are certified as MRSA-free.

The determination of the MRSA prevalence in Swiss pig herds based on single pig testing at slaughter, which leads to an imprecise estimation of prevalence at the farm level. However, sampling at farm level is much more time-consuming and costly. Alternatively, defining MRSA status at herd level, followed by subsequent control measures during the entire production cycle, could lead to a more accurate determination of MRSA prevalence, even with sampling at the slaughterhouse. Additionally, it should also be envisaged to examine the status of methicillin-sensitive *Staphylococcus aureus* (MSSA) in pig farming which may also be resistant to multiple antibiotics and possibly harbour virulence factors like Panton-Valentine leukocidin or other toxins.

## 5. Conclusions

Intermittent colonisation throughout the entire production cycle was conspicuous in the tracking of MRSA at the level of the individual pig. This implies that pigs are transiently rather than permanently colonised and suggests repeated contamination. As a consequence, the MRSA status should be defined at the herd level instead of individual pigs. As the prevalence in Swiss slaughter pigs is constantly increasing, the further spread of MRSA could be prevented by defining farms as MRSA positive or negative and allowing the trade of animals only within herds of the same status. With the implementation of these measures, also further dissemination of LA-MRSA into healthcare facilities and the community via humans with close contact to these animals, i.e., farmers, veterinarians and slaughterhouse workers could be prevented.

## Conflict of interest

None.

## Acknowledgements

We are grateful to all farmers and staff who granted access to their farms and their kind cooperation; to the slaughterhouse managers and their team, who provide the access to the slaughterhouses and the organisation of taking samples from animals and their facility; to the lorry-drivers for their patience and their permission taking samples of the vehicle; to Patricia Hirsiger, Bettina Jenny, Julia Malik, Dolf Kümmerlen and Wolfgang Pendl, Vetsuisse Faculty, University of Zurich, Switzerland, Saria In-Albon, Julia Furrer, Bettina Meuli, Claudio Dolder and Thomas Mock, Vetsuisse Faculty, University of Bern, Switzerland, for their assistance in taking samples on farms and slaughterhouse; and to Isabelle Brodard and Susanne Rickli, Vetsuisse Faculty, University of Bern, Switzerland, for excellent technical support. This study was financed by a research grant of the Swiss Federal Food Safety and Veterinary Office (FSVO), grant number 1.14.k.

## References

- Broens, E.M., Espinosa-Gongora, C., Graat, E.A., Vendrig, N., van der Wolf, P.J., Guardabassi, L., Butaye, P., Nielsen, J.P., de Jong, M.C., van de Giessen, A.W., 2012. Longitudinal study on transmission of MRSA CC398 within pig herds. *BMC Vet. Res.* 8, 58.
- Broens, E.M., Graat, E.A., van der Wolf, P.J., van de Giessen, A.W., de Jong, M.C., 2011. Transmission of methicillin resistant *Staphylococcus aureus* among pigs during transportation from farm to abattoir. *Vet. J.* 189, 302–305.
- Burns, A., Shore, A.C., Brennan, G.L., Coleman, D.C., Egan, J., Fanning, S., Galligan, M.C., Gibbons, J.F., Gutierrez, M., Malhotra-Kumar, S., Markey, B.K., Sabirova, J.S., Wang, J., Leonard, F.C., 2014. A longitudinal study of *Staphylococcus aureus* colonization in pigs in Ireland. *Vet. Microbiol.* 174, 504–513.
- Büttner, S., Mehmman, M., Müntener, C., Torriani, K., Overesch, G., 2014. Bericht über den Vertrieb von Antibiotika in der Veterinärmedizin und das Antibiotikaresistenzmonitoring bei Nutztieren in der Schweiz (ARCH-VET 2013) (<http://www.blv.admin.ch>).
- Crombé, F., Argudin, M.A., Vanderhaeghen, W., Hermans, K., Haesebrouck, F., Butaye, P., 2013. Transmission dynamics of methicillin-resistant *Staphylococcus aureus* in pigs. *Front. Microbiol.* 4, 57.
- Dewaele, I., Messens, W., De Man, I., Delputte, P., Herman, L., Butaye, P., Heyndrickx, M., Rasschaert, G., 2011. Sampling, prevalence and characterization of methicillin-resistant *Staphylococcus aureus* on two Belgian pig farms. *Vet. Sci. Dev.* 1.
- de Neeling, A.J., van den Broek, M.J.M., Spalburg, E.C., van Santen-Verheuevel, M.G., Dam-Deisz, W.D.C., Boshuizen, H.C., van de Giessen, A.W., van Duijkeren, E., Huijsdens, X.W., 2007. High prevalence of methicillin resistant *Staphylococcus aureus* in pigs. *Vet. Microbiol.* 122, 366–372.
- Eriksen, N.H., Espersen, F., Rosdahl, V., Jensen, K., 1995. Carriage of *Staphylococcus aureus* among 104 health persons during a 19-month period. *Epidemiol. Infect.* 115, 51–60.
- Köck, R., Loth, B., Köksal, M., Schulte-Wülwer, J., Harlizius, J., Friedrich, A.W., 2012. Persistence of nasal colonization with livestock-associated methicillin-resistant

- Staphylococcus aureus* in pig farmers after holidays from pig exposure. *Appl. Environ. Microbiol.* 78, 4046–4047.
- Lewis, H.C., Mølbak, K., Reese, C., Aarestrup, F.M., Selchau, M., Sørum, M., Skov, R.L., 2008. Pigs as source of methicillin-resistant *Staphylococcus aureus* CC398 infections in humans, Denmark. *Emerg. Infect. Dis.* 14, 1383–1389.
- Nouwen, J., Boelens, H., van Belkum, A., Verbrugh, H., 2004a. Human factor in *Staphylococcus aureus* nasal carriage. *Infect. Immun.* 72, 6685–6688.
- Nouwen, J.L., Ott, A., Kluytmans-Vandenbergh, M.F., Boelens, H.A., Hofman, A., van Belkum, A., Verbrugh, H.A., 2004b. Predicting the *Staphylococcus aureus* nasal carrier state: derivation and validation of a culture rule. *Clin. Infect. Dis.* 39, 806–811.
- Nouwen, J.L., Fieren, M.W., Snijders, S., Verbrugh, H.A., van Belkum, A., 2005. Persistent (not intermittent) nasal carriage of *Staphylococcus aureus* is the determinant of CPD-related infections. *Kidney Int.* 67, 1084–1092.
- Overesch, G., Büttner, S., Perreten, V., 2012. Evolution of methicillin-resistance *Staphylococcus aureus* (MRSA). *Fleischwirtsch. Int.* 6, 61–63.
- Stegger, M., Lindsay, J.A., Moodley, A., Skov, R., Broens, E.M., Guardabassi, L., 2011. Rapid PCR detection of *Staphylococcus aureus* clonal complex 398 by targeting the restriction-modification system carrying *sauI-hsdS1*. *J. Clin. Microbiol.* 49, 732–734.
- Van Cleef, B., Graveland, H., Haenen, A., Van de Giessen, A., Heederik, D., Wagenaar, J., Kluytmans, J., 2011. Persistence of livestock-associated methicillin-resistant *Staphylococcus aureus* in field workers after short-term occupation exposure to pigs and veal calves. *J. Clin. Microbiol.* 49, 1030–1033.
- van Rijen, M.M.L., van Keulen, P.H., Kluytmans, J.A., 2008. Increase in a Dutch Hospital of methicillin-resistant *Staphylococcus aureus* related to animal farming. *Clin. Infect. Dis.* 46, 261–263.
- VandenBergh, M.F., Yzerman, E.P., van Belkum, A., Boelens, H.A., Sijmons, M., Verbrugh, H.A., 1999. Follow-up of *Staphylococcus aureus* nasal carriage after 8 years: redefining the persistent carrier state. *J. Clin. Microbiol.* 37, 3133–3140.
- Verheghe, M., Pletinckx, L.J., Crombe, F., Van Weyenberg, S., Haesebrouck, F., Butaye, P., Heyndrickx, M., Rasschaert, G., 2013. Cohort study for the presence of livestock-associated MRSA in piglets: effect of sow status at farrowing and determination of the piglet colonization age. *Vet. Microbiol.* 162, 679–686.
- Verkade, E., Kluytmans, J., 2014. Livestock-associated *Staphylococcus aureus* CC398: animal reservoirs and human infections. *Infect. Genet. Evol.* 21, 523–530.
- Voss, A., Loeffen, F., Bakker, J., Klaassen, C., Wulf, M., 2005. Methicillin-resistant *Staphylococcus aureus* in pig farming. *Emerg. Infect. Dis.* 11, 1965–1966.
- Weese, J.S., Zwambag, A., Rosendal, T., Reid-Smith, R., Friendship, R., 2011. Longitudinal investigation of methicillin-resistant *Staphylococcus aureus* in piglets. *Zoonoses Public Health* 58, 238–243.
- Wertheim, H.F.L., Melles, D.C., Vos, M.C., van Leeuwen, W., van Belkum, A., Verbrugh, H.A., Nouwen, J.L., 2005. The role of nasal carriage in *Staphylococcus aureus* infections. *Lancet. Infect. Dis.* 5, 751–762.
- Wettstein Rosenkranz, K., Rothenanger, E., Brodard, I., Collaud, A., Overesch, G., Bigler, B., Marschall, J., Perreten, V., 2014. Nasal carriage of methicillin-resistant *Staphylococcus aureus* (MRSA) among Swiss veterinary health care providers: Detection of livestock- and healthcare-associated clones. 156, 317–325.
- Williams, R.E., 1963. Healthy carriage of *Staphylococcus aureus*: its prevalence and importance. *Bacteriol. Rev.* 27, 56–71.